

SPECIFICATION

1. PHYSICAL DIMENSION(UNIT: m/m):

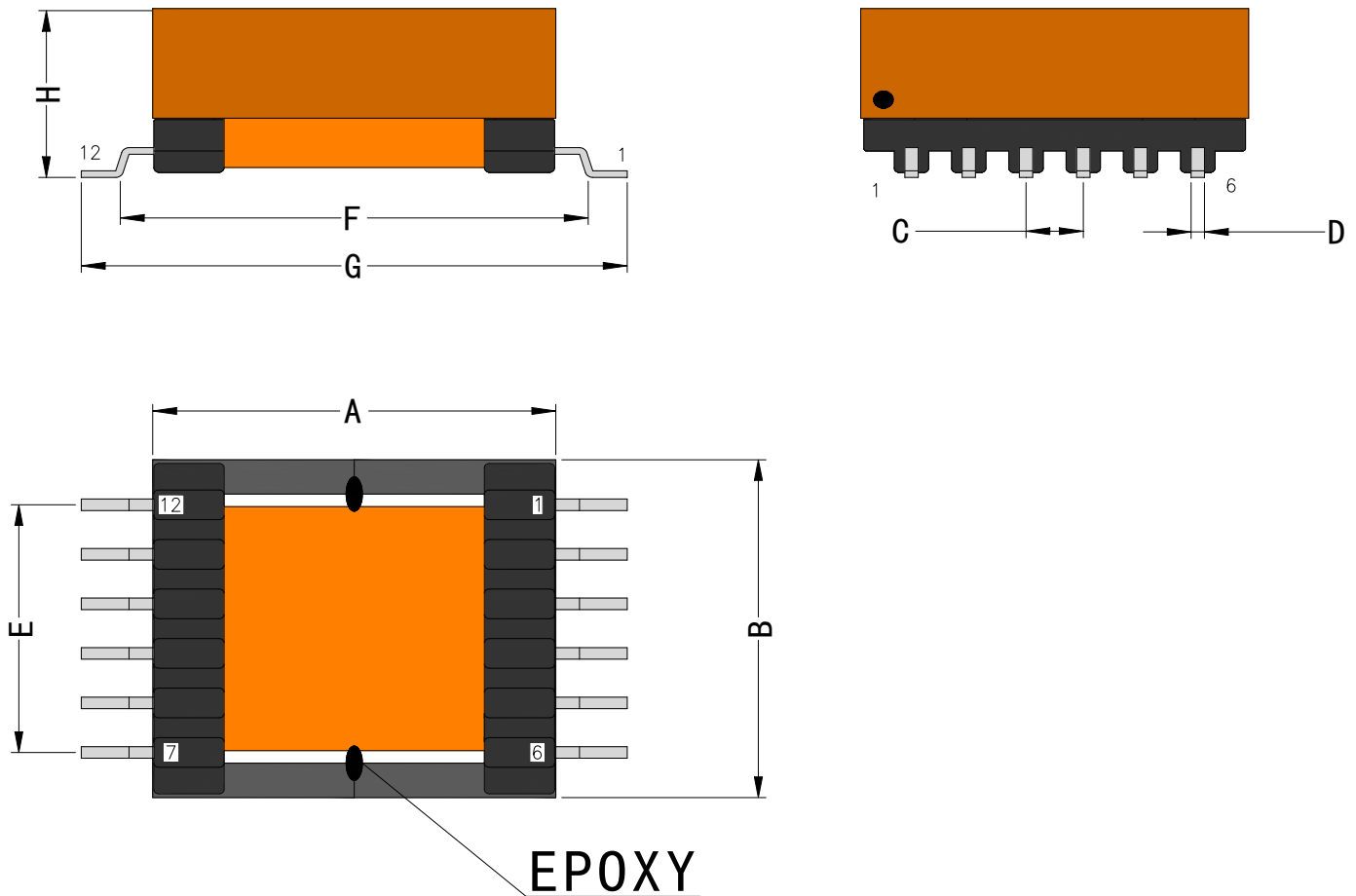

- ※DIMENSIONS WITHOUT TOLERANCE ARE APPROX
- ※DIMENSION DOES NOT INCLUDE SOLDER USED ONCOILS

LEAD FREE

DIM	A	B	C	D	E	F	G	H				
	MAX	MAX	+/-0.5	+/-0.1	+/-0.5	REF	+/-1.5	MAX				
SPEC	22.0	22.0	3.0	0.7	15.0	24.6	30.0	12.0				
						DESCRIPTION		TRANSFORMER				
						Customer P/N						
						FERRIWO P/N		FW-EFD20SMD-570K				
SPEC. NO.	PS-1001-007				PREPARED				APPROVED			

SPECIFICATION

2.WINDING TABLE:

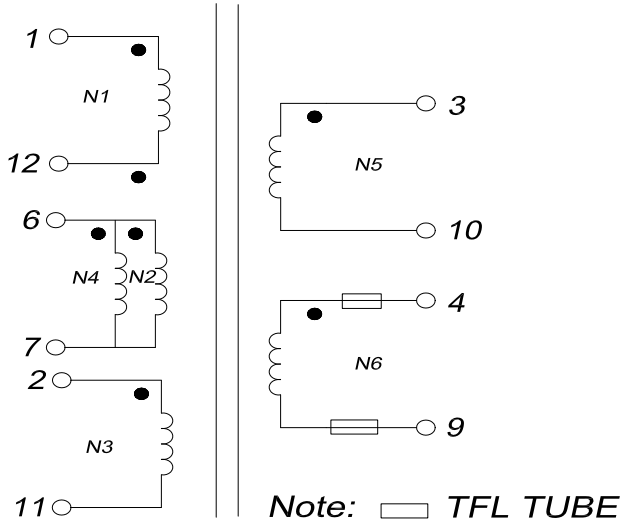

3.WINDING:

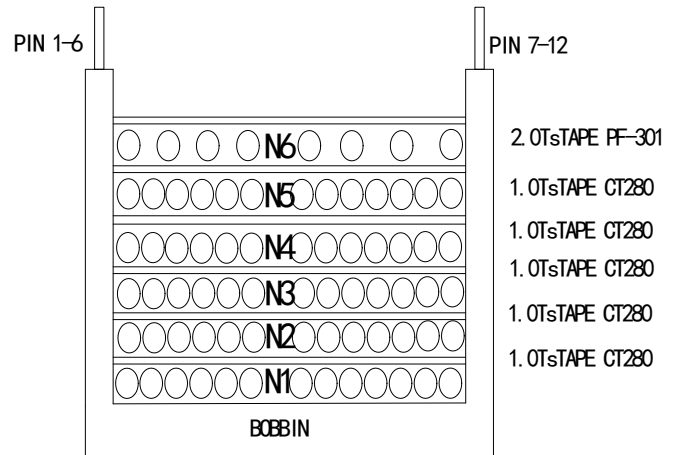

4.WINDING TABLE:

Winding NO.	Margin Tape	PIN	Wire & Wire Copper	Turns	Winding Type	Tape Layer	Tube
N1	0	1~12			Compact	1	0
N2	0	6~7			Compact	1	0
N3	0	2~11			Compact	1	0
N4	0	6~7			Compact	1	0
N5	0	3~10			Compact	1	0
N6	0	4~9			Dispersed	2	F=S≈10mm

NOTE:

1. Products should be vacuum impregnation
 - *VARNISH RATIO: 1:1
 - *VACUUM TIME: 15~20minutes
 - *BAKED TEMPERATURE : 120°C±10°C, 1~1.5hours

LEAD FREE

DESCRIPTION	TRANSFORMER
Customer P/N	
FERRIWO P/N	FW-EFD20SMD-570K

SPEC. NO.	PS-1001-007	PREPARED	APPROVED
-----------	-------------	----------	----------

SPECIFICATION

5. ELECTRONICAL CHARACTERISTIC:

TEST CONDITION : TEMPERATURE AT 25°C
HUMIDITY AT 65 ±5% RH

TEST ITEM	TEST CONDITION	RESULT
INDUCTANCE CH-3250	@1.0KHz,1.0V (6~7)	57.0uH±10%
D.C.R TH2513A	@at25°C (6~7)	200.0mΩ MAX
HI-POT TEST CH-9052	@ 1mA 2SEC (AC) 50Hz	P<->S 1.5 KV; P、S<-> CORE 0.5KV;

LEAD FREE

		DESCRIPTION	TRANSFORMER
		Customer P/N	
		FERRIWO P/N	FW-EFD20SMD-570K
SPEC. NO.	PS-1001-007	PREPARED	APPROVED

SPECIFICATION

6. MATERIAL LIST :

ITEM		MATERIAL	SUPPLIER OR MANUFACTURER	TEMPRATING
1	CORE	FW44 OR EQUIVALENT	HAINING FERRIWO ELECTRONICS CO., LTD.	
2	BOBBIN	PHENOLIC OR EQUIVALENT	SUMITOMO BAKELITE CO., LTD. UL NO E41429	150°C
3	WIRE	UEW	PACIFIC ELECTRIC WIRE&CABLE(SHENZHEN) CO. LTD UL NO E84081	130°C
4	TAPE	PF-301	YAHUA STICKING TAPE CO.,LTD UL NO E165111	180°C
		CT280		130°C
5	VARNISH	R-1038	JOHN C DOLPH CO BC-346A UL NO E317427	130°C
6	TUBE	TEFLON TUBE	GREAT HOLDING INDUSTRIAL CO.,LTD UL NO E156256	200°C
7	FLUX	TF9100	LINAN GUITONG CHEMICAL TECHNICAL CO.,LTD	
8	TIN	Sn99.3Cu0.7	HAINING ZHUCHANG METAL FOIL CO;LTD	
9	EPOXY	E-500 (BLACK)	SUZHOU EATTO ELECTRONIC MATERIAL CO.,LTD UL NO E218090	130°C

LEAD FREE



DESCRIPTION

TRANSFORMER

Customer P/N

FERRIWO P/N

FW-EFD20SMD-570K

SPEC. NO.

PS-1001-007

PREPARED

APPROVED